

Z 11

Z 22

Z 33

Z 44

# centrifugal

## Centrifugal Finishers



**SPALECK**  
Oberflächentechnik



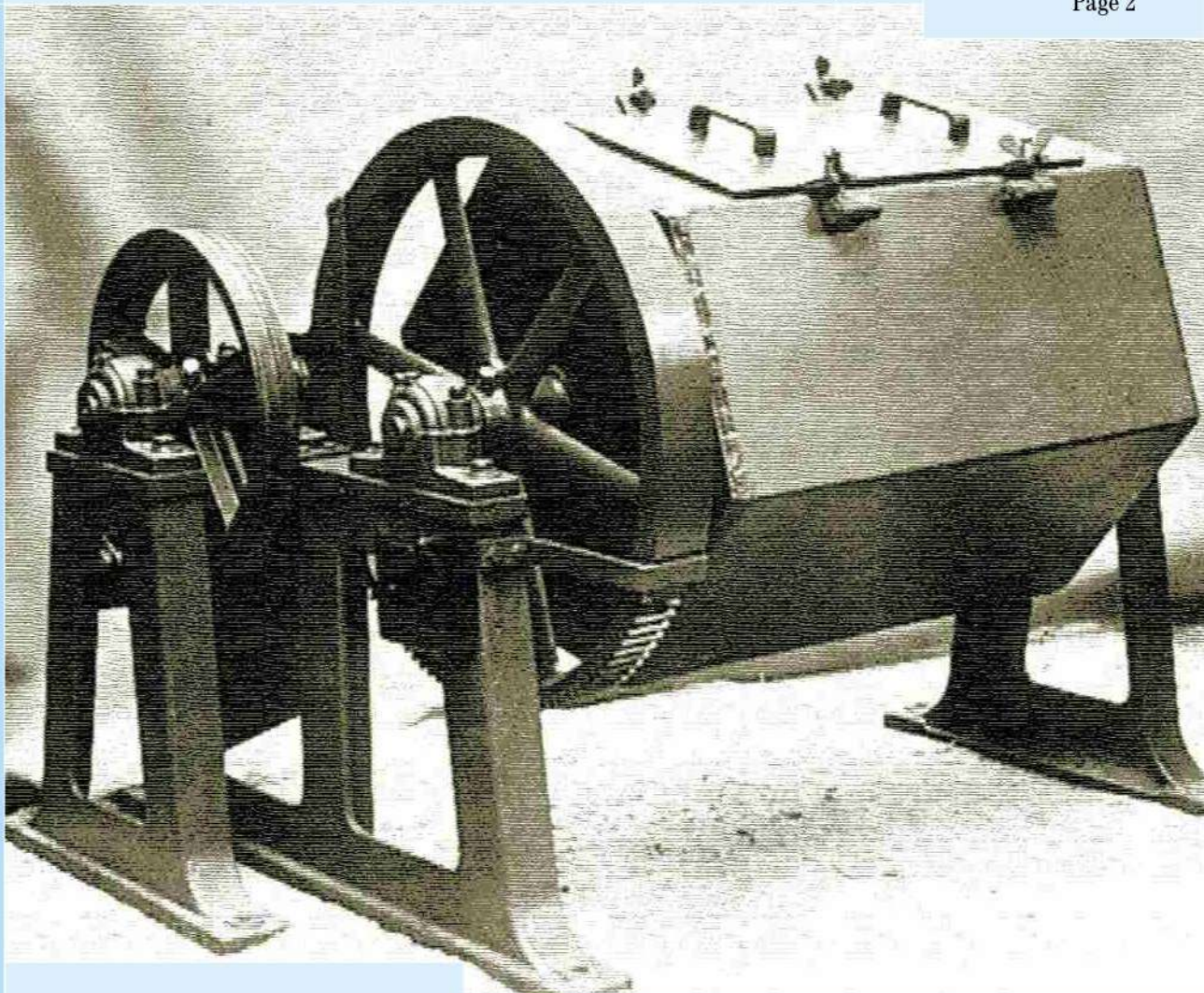

Contents:

page 3  
„With the innovation of pioneers...“

page 5  
„You want your products to rank among the best? With SPALECK centrifugal finishers, you'll set new standards!“

page 7  
„Your ultimate goal is profit? SPALECK centrifugal finishers yield top results – in terms of finish and money!“

page 9  
„Your spectrum becomes wider. SPALECK centrifugal finishers advance the technology!“

page 10  
„The unique SPALECK technology for better production!“

page 12  
„Expand your SPALECK centrifugal finishing installation at any time – thanks to its modular construction!“

page 14  
Z 11, Z 22, Z 33, Z 44

page 16  
„SPALECK – a world of surface finishing techniques!“

page 16  
„Any further questions?“

pioneers

With the innovation of pioneers...



## Since over 80 years

# Production of SPALECK Centrifugal Finishers!

Experience does not have to be the one criterion for a cooperation with other companies, but it certainly is an asset.

SPALECK has been offering installations for surface treatment for some 80 years now. Numerous patents during this time span bespeak the unparalleled innovative force of this company.

Our products are being used all over the world for the deburring, grinding, radiusing, polishing, smoothing and cleaning of all kinds of parts.

### Each part being different...

...we will develop the best combination of machine and process for your application. Laboratories, sample treatment centers and last but not least our highly motivated team of specialists guarantee best results for your products.

### Take a look at our program...

Accepting our responsibility to keep you on the safe side, we offer a complete range of machines, products and accessories up to the recycling of processing liquids:

- ▲ Machines for surface finishing
- ▲ Media (abrasives)
- ▲ Chemicals (compounds)
- ▲ Peripheral units for loading, unloading, separation, washing, drying, etc.
- ▲ Recycling systems for processing liquids

The entire program is based on a modular concept, enabling you to obtain standalone machines or units, as well as complete, computer-controlled treatment centers.

### ...the best in manufacture

What could be more important to you than your own products? You are looking for the best possible quality – we are offering solutions tailored to your requirements: manufactured entirely at SPALECK.

### ...and all this quite close to you:

We're here to serve our customers, to serve you.

With our head office in Bocholt and numerous branches around the world we are but a phone call away.

**Give us a call - we will be there.**



From 0.2 mm on up nearly everything is possible.

**We have the technology. We have the experience. We have ideas.  
SPALECK centrifugal finishers are the innovation.**

new stan



You want your products to rank among the best?  
**With SPALECK centrifugal  
 finishers you'll set new standards!**

Surface finishing is the indispensable technique for the deburring, radiusing, grinding, descaling or polishing of parts. SPALECK surface finishing improves the appearance of any surface, regardless of the look of the parts.

**Our new generation of centrifugal finishers improves your results:**

The treatment intensity is up to 20 times higher as compared to vibratory finishing with an indisputably broader range of applications as compared to conventional centrifugal finishers.

▲ **Now, you can even treat parts with a thickness of only 0.2 mm on up!**

**How can you be sure?**

In our testing labs, we check the treatment parameters of your parts under realistic conditions. We determine the correct machine size for your production capacity, the required compounds, the correct shape and type of abrasives. Where required, we develop new techniques or processes. In short, we'll put everything in motion so your products will compare to the best on the market.



We make your problem our challenge –  
 quality should never be a compromise!



SPALECK centrifugal finishers – real value for money

**What use is a good looking piece of machinery if it does not perform or survive years of continuous operation...?  
SPALECK centrifugal finishers – reliability for many years to come.**

shining



## Your ultimate goal is profit?

# SPALECK centrifugal finishers yield top results – in terms of finish and money!

**In the development of our new generation of centrifugal finishers, a particularly favourable price / performance ratio was our main objective.**

**Important considerations were the time the installation would actually be working, and how much time would be lost between batches for loading, unloading, for screen changes or the exchange of wear parts.**

**Our new centrifugal finishers set standards in profitability:**

- ▲ The machines are set up in no time.
- ▲ The treatment parameters can be preprogrammed and selected by the simple push of a button.
- ▲ A fully automatic mode reduces idle times to the absolute minimum.
- ▲ The multiple-batch system further increases the productivity of the unit.
- ▲ Tub and rotor are quickly disassembled, without the need to remove the drive first.
- ▲ **Adjustment and control of the gap are automatically effected saving up to 30 minutes each time as compared to conventional installations of this kind.**

And there is another advantage SPALECK centrifugal finishers have to offer. For more than 20 years, all wear parts concerning tub and rotor have been interchangeable – despite redesigns of the machines.

Tubs and rotors of your old SPALECK machine park can be used in new machines without modification.

**Continuity as a service to our customers.**



Top results in terms of finish and money.

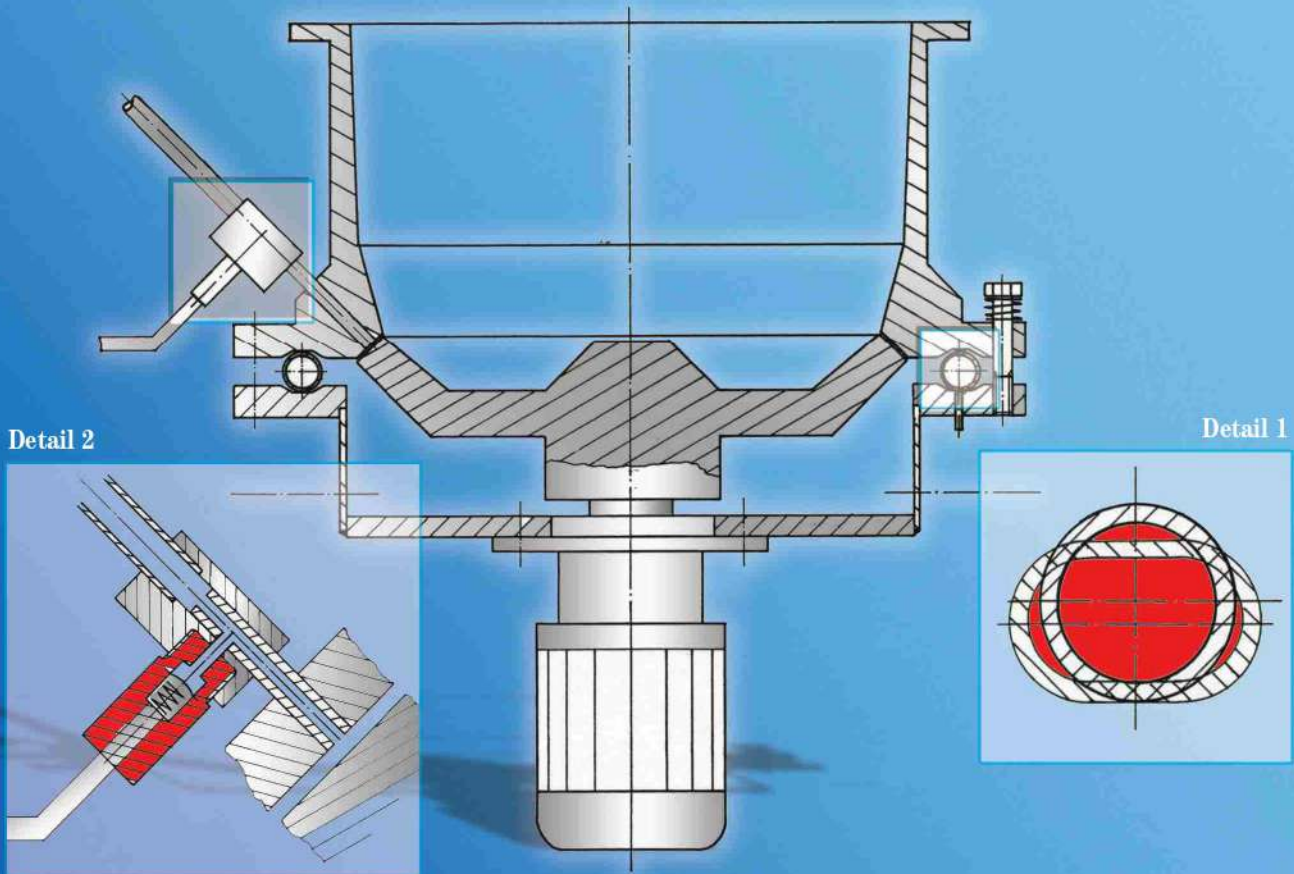

The most sensitive area of any centrifugal finisher is the gap between the working tub and rotor. Gap geometry, its setting and control are the decisive factors for operational dependability and service life of the installation. Through intensive, basic research, SPALECK has developed a patented solution, which works as follows:

A circular pressure hose (1) serves to adjust the gap width. The preset value is controlled with a probe (2). This is the automatic gap control – fully automatic, PLC controlled, perfectly simple.

**Perfect results are largely a reflection of technology...  
This technology is found in SPALECK centrifugal finishers.**

advantage





Your spectrum becomes wider.

# SPALECK centrifugal finishers advance the technology!

**If your primary goal is to secure a market share, the technical superiority and the quality standard of production machinery play an important role.**

Therefore, we suggest you forget everything you have heard about centrifugal finishing, because SPALECK can offer you technical innovations which will revolutionize centrifugal finishing in terms of profitability, simplicity and safety:

- ▲ SPALECK centrifugal finishers have been designed with a special geometry of working tub and rotor for an intense treatment in the shortest possible time.
- ▲ With our automatic gap setting and gap control, manual adjustment of the gap has become a thing of the past.
- ▲ SPALECK centrifugal finishers obtain a wobble of the rotor of only  $\pm 0.025$  mm.  
This high degree of concentricity is extremely important for the reliability and service life of the machine.
- ▲ SPALECK measures the process temperature directly in the processing liquid as a safety feature to ensure the shortest possible reaction time to programmed shutdown.
- ▲ SPALECK offers the infinitely variable rotor speed for all centrifugal finisher types already as standard equipment.
- ▲ SPALECK has designed a discharging angle of the working tub of  $180^\circ$  to guarantee 100% unloading.
- ▲ SPALECK incorporates an infinitely variable setting of the processing liquid level inside the working tub for the treatment of delicate parts ...

...and there is much more.

**The following pages will tell you more about our installations, technical details and what else we have to offer.**

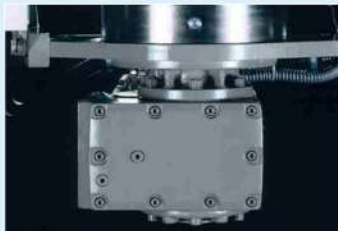

The special bearing (greased for life) ensures an optimum concentricity.

# The unique SPALECK technology for better production!

## 1. Short treatment times

Thanks to its special working tub geometry and the particular shape of the rotor, SPALECK centrifugal finishers permit a very intensive treatment and the shortest possible cycle times. The multiple-batch-operation – simultaneous treatment of parts and separation of the previous batch – guarantees a minimum of idle times.

## 2. Standard: the automatic gap adjustment

Before the start of each cycle, the SPALECK automatic gap adjustment automatically readjusts the gap between tub and rotor to a preset value. For this purpose, the gap is completely opened, then

▲ rinsed with the rotor turning    ▲ closed completely (reset to 0)    ▲ adjusted to the preset value

## 3. Automatic gap control

This system controls and regulates the gap width constantly during the entire treatment cycle, thus even compensating for thermal expansion of the polyurethane lining. At the same time, the gap is rinsed. Total reliability, minimal wear and the time savings as compared to manual systems are convincing advantages.

## 4. Extremely low wobble of the rotor

The heavy duty, special bearing and the finishing accuracy of the rotor guarantee a concentricity of  $\pm 0.025$  mm. In laymen's terms: the rotor runs true. This is particularly important, as it avoids the generation of a varying gap width between tub and rotor. Thus, a jamming of splinters or thin parts is virtually impossible.

## 5. Temperature control

We measure the process temperature directly in the processing liquid. The reaction of the machine to excessive temperatures can be very fast, and this control stops the machine immediately to avoid any damage to the gap.

## 6. Adjustable rotor speed – infinitely

Even in our standard versions, the rotor speed of our centrifugal finishers adjusts electronically and is infinitely variable.

## 7. Infinitely variable level control inside the working tub



The tilting angle of  $180^\circ$  permits a complete unloading of the working tub.

Don't accept anything less. The electronically controlled, infinitely variable level control of the processing liquid inside the working tub permits an infinitely variable adjustment of the treatment intensity, the treatment of very delicate parts as well as an absolutely uniform surface appearance on the parts. Adhesion of parts, and of flat parts in particular, is eliminated.

An optional extension of this system can provide a fast prefill of the tub.

## 8. Complete unloading of the working tub

The hydraulic rotary drive permits a tilting of the tub of  $180^\circ$  for 100% unloading. Minimum drop heights result in careful transfer points.



Automatic gap control.



The tilting angle of 180° permits a complete unloading of the working tub.

### 9. Simple exchange of the treatment unit

Even when wear parts have to be replaced, you will find out what we mean by convenience. Working tub, tub segments, rotor, drive bearings and gear are simply flanged together and are self-centering. Each individual part has been standardized and can be delivered ex stock in our exchange program.

### 10. Separate even more effectively

In order to make the maximum separation area available, we have equipped our separation unit with an undersize screen on a second level. This saves space and permits you to sort out undersize media effectively.

### 11. Safety and comfort thanks to programmable logic controller (PLC)

SPALECK centrifugal finishers are available with PLC for a fully automatic processing. Depending on the individual requirements, several treatment programs can be stored, with the PLC automatically setting all regulating and control values:

- |                                 |  |
|---------------------------------|--|
| ▲ rotor speed                   | ▲ gap setting                                    |
| ▲ critical process temperature  | ▲ treatment time                                 |
| ▲ separation time               | ▲ processing liquid level inside the working tub |
| ▲ type and quantity of compound | ▲ number and duration of rinsing cycles          |



Separation on two levels – parts on the upper and undersize media on the lower level.

A comfortable display for operator guidance indicates all operator information and error messages in the respective language.



PLC for automatic operation.

### 12. Operator friendly: easily accessible machines

SPALECK centrifugal finishers offer the advantage of extremely low height. At any given time, the operator has access to all parts of the installation to watch the process, to manually remove or add parts to the process, etc. Safety mats guarantee protection against accidents. Once stepped on, they immobilize critical movements, such as the tilting of tub or dumper – without disrupting the treatment process.



Ergonomic arrangement of machine heights.

### 13. Surface finishing without effluent discharge – with SPALECK, no problem!

The SPALECK recycling systems keep your processing liquids in a closed circuit. All you have to do is compensate for liquid losses due to evaporation or entrainment. Parts and media residues are recovered as a solid filter cake. On balance, recycling can save you a lot of money – another topic worth talking about.



Recycling centrifuge ZMT.

# Expand your SPALECK centrifugal finishing installation at any time – thanks to its modular construction!

Surface finishing alone does not produce the final part, but is one step in the production.

SPALECK offers everything necessary for the surface refinement of your parts and their economic production – as a modular concept:

- ▲ Everything fits together
- ▲ Everything based on the effective SPALECK technology
- ▲ Everything of reliable SPALECK quality

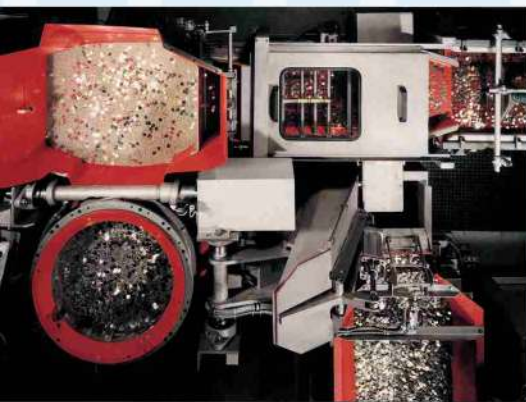

The components are tried and tested, the solution is always one hundred percent tailor-made to suit the specific customer requirements.

All these elements can be combined to become a customised installation to meet your technical requirements.

- ▲ Basic machine
- ▲ 2nd basic-machine as add-on for a tandem version
- ▲ Loading unit
- ▲ Vibratory conveyor
- ▲ Vibratory screening device
- ▲ Processing liquid level control
- ▲ Automatic gap control
- ▲ Thermal cut-out due to excess processing liquid temperatures
- ▲ Overflow guard
- ▲ Fast prefill of working tub
- ▲ Infinitely variable spinner speed
- ▲ Safety mats
- ▲ Sound insulation
- ▲ PLC-control, alternatively push-button control
- ▲ Magnetic separators, with or without demagnetisation
- ▲ Recycling systems for processing liquids
- ▲ Roundtub driers

Roundtub drier VAT.



Recycling centrifuge ZMT.



Double separation with magnetic separators MSE and MS.



Z33 basic machine or add-on for a Z33 tandem installation.



Centrifugal finisher Z33, complete system.

Vibratory conveyor SFM (optionally available with weigh scale) and vibratory screening device VSM.



Loading hopper BKA.



# Technical Data

Technical Data:	Z 11	Z 22	Z 33	Z 44
Nominal vol. standard	60 l (2.1 cu. ft.)	110 l (3.9 cu. ft.)	180 l (6.3 cu. ft.)	260 l (9.1 cu. ft.)
Nominal vol. tandem	120 l (4.2 cu. ft.)	220 l (7.8 cu. ft.)	360 l (12.6 cu. ft.)	520 l (18.2 cu. ft.)
Working vol. standard*	up to approx. 40 l	up to approx. 70 l	up to approx. 120 l	up to approx. 210 l
Working vol. tandem*	up to approx. 80 l	up to approx. 140 l	up to approx. 240 l	up to approx. 420 l
Rotor speed	100 – 220 rpm, infinitely variable	100 – 220 rpm, infinitely variable	100 – 215 rpm, infinitely variable	80 – 160 rpm, infinitely variable
Gap width	≥ 0,2 mm infinitely variable	≥ 0,2 mm infinitely variable	≥ 0,2 mm infinitely variable	≥ 0,2 mm infinitely variable
Unloading angle	approx. 160°	approx. 180°	approx. 180°	approx. 180°
Rotor drive output	2,2 (3) kW	4,0 (5,5) kW	7,5 (9,2) kW	18,5 (22) kW
<b>Total connected load:</b>				
Standard	5,6 kW	7,5 kW	11 kW	28 kW
Tandem	10,5 kW	14,3 kW	21,3 kW	54 kW
Operating voltage	400 V, 50 Hz	400 V, 50 Hz	400 V, 50 Hz	400 V, 50 Hz

\* The capacity of the installation is determined by the treatment intensity, the cycle time and the non-productive time in connection with the working volume.

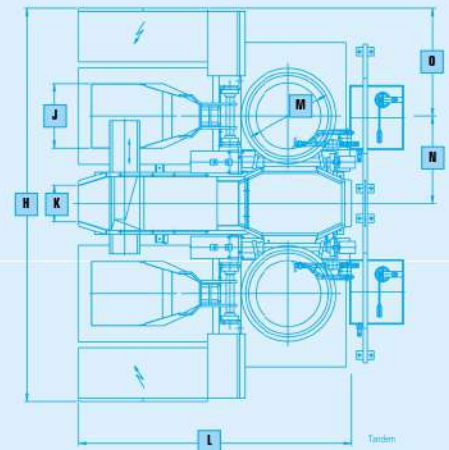
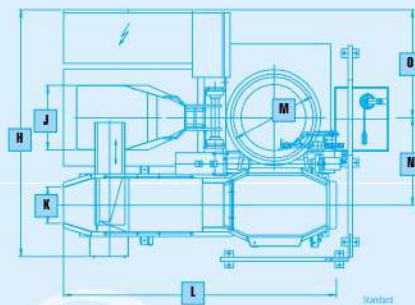
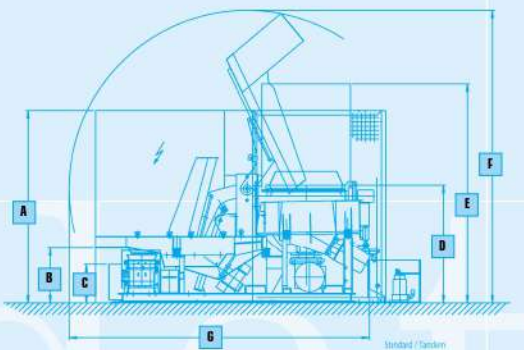

Dimensions	Z 11	Z 11 tandem	Z 22	Z 22 tandem	Z 33	Z 33 tandem	Z 44	Z 44 tandem
A	1800	1800	1800	1800	1800	1800	2200	2200
B	500	500	510	510	510	510	770	770
C	360	360	360	360	360	360	610	610
D	1000	1000	1100	1100	1100	1100	1500	1500
E	1750	1750	1950	1950	2050	2050	2700	2700
F	2500	2500	2700	2700	2750	2750	3300	3300
G	2500	2500	2800	2800	2800	2800	3500	3500
H	2100	3300	2300	3620	2300	3620	2900	4700
J	470	470	500	500	600	600	780	780
K	240	240	330	330	330	330	330	330
L	2340	2340	2550	2550	2550	2550	3700	3700
M	600	600	690	690	830	830	1080	1080
N	700	700	785	785	815	815	1100	1150
O	950	950	1030	1030	1000	1000	1200	1200

Subject to technical modifications.

Our machines are strictly built in accordance with your requests – for an optimum use of your capacities we offer large machines for continuous operation as well as small ones for low numbers of pieces.

## Z 33 tandem

Z33 in tandem design with multibatch system to minimize stoppage times.

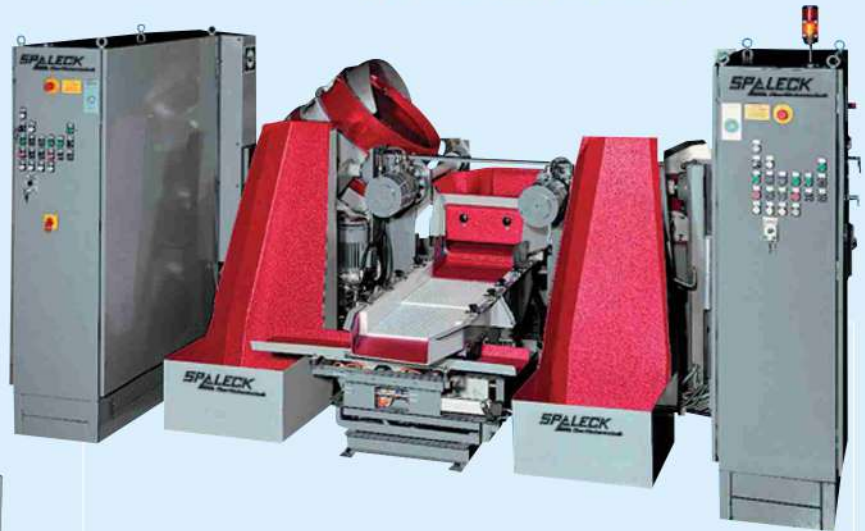

The small series Z for low numbers of pieces.

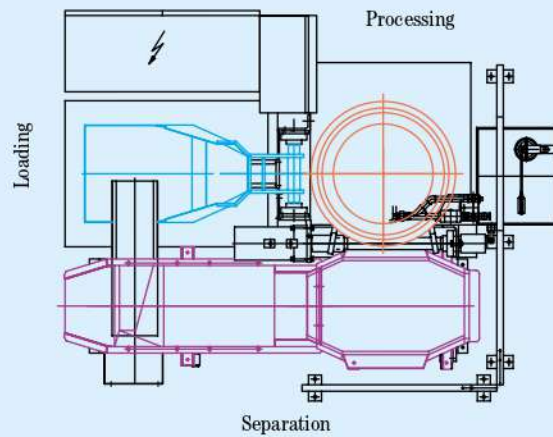

## Z 11



# SPALECK - a world of surface finishing techniques



**Any questions left?  
Give us a call or write to us.  
We will be happy to  
be of service!**

## **Machines:**

- ▲ Roundtub vibrators
- ▲ Centrifugal finishers
- ▲ Throughfeed vibrators
- ▲ Tumbling barrels
- ▲ Finishing barrels
- ▲ Vibratory driers
- ▲ Hot air tunnel driers
- ▲ Magnetic separators
- ▲ Loading and unloading units
- ▲ Sound insulating systems
- ▲ Effluent treatment
- ▲ Recycling systems
- ▲ Fully automatic plants
- ▲ Standard machines
- ▲ Conveying and separation systems

## **Media:**

- ▲ Abrasives
- ▲ Compounds
- ▲ Drying granulates
- ▲ Polishing media

## **Service:**

- ▲ Sample treatment – free of charge
- ▲ Application consulting
- ▲ Process technology
- ▲ Engineering
- ▲ Waste water analyses
- ▲ Service on location
- ▲ Maintenance contracts



**SPALECK**  
Oberflächentechnik

SPALECK Oberflächentechnik GmbH + Co. KG  
Postfach 2253 · D-46372 Bocholt  
Schleiverhorst 117 · D-46395 Bocholt  
Telefon +49 (0) 28 71 / 95 00-0  
Telefax +49 (0) 28 71 / 95 00-95  
www.spaleck.biz · info@spaleck.biz